



Corporate Profile
© 2020

Website: www.northstoneshelters.com

Table of Contents

- **Welcome**
- **About Us**
- **Key Organisation Values**
- **Organisation Ethics**
- **Our Mission/Our Vision**
- **Our Expertise**
- **Organisation Chart**
- **Our Projects**
- **Our Clients**
- **Certifications**



Welcome

We sincerely appreciate you taking the time to go through our Corporate profile. This is a great opportunity for us to communicate our services and key competitive strengths to you.

This profile is designed to provide you with a brief introduction to Northstone Shelters Limited, and to educate you on our professional capabilities. We look forward to meeting you personally in order to develop a mutually beneficial business relationship.

Since our inception in 2015, we have developed a trusted and reliable construction company that has remained committed to proffering high quality shelter solutions to the Nigerian populace and the continent of Africa in general.

We appreciate your sincere interest in Northstone Shelters Limited and we look forward to working with you.





About Us

We have the pleasure of introducing the above mentioned company to your reputable organization. Northstone Shelters Limited is a consortium of highly skilled professionals, committed to proffering high quality shelter solutions to the Nigerian populace and the continent of Africa in general.

Within our short years of existence as Northstone Shelters Limited, we have successfully demonstrated our ability to understand and implement all kinds of projects to our growing list of clientele in government & private sectors thus securing an enviable reputation for unrivaled quality & technically sophisticated structures.

Our capability and expertise in project design, implementation & management has been evident in the implementation of several completed projects. We have been privileged to handle such as high rise buildings, commercial and residential towers, hotels, schools, hospitals and shopping malls.

We leverage on our strong dedication to superior client service, by listening to the needs of our clients and tailoring our skills to match these needs using the best equipments and the most cost-effective methods in the 21st century.

With our vast experience and excellent track records using innovative building methods, we have positioned ourselves as the ideal shelter solution partner for all residential and commercial projects. We have also retained our commitment to the highest level of ethics, integrity, professionalism & excellence in all phases of our operations.

Our services adds class to our customers and it's also very competitive therefore we solicit your permission to render this quality and dedicated service to your reputable organization.

Yours faithfully

Oluwasegun Olubodun
Principal Partner

Key Organization Values

Ethics

We have remained true to our founding values of delivering high quality, durable, technically sophisticated structures to our clients.

We endeavour to adhere to the highest ethical standards in the industry. Therefore we have been consistently associated with integrity, high quality standards of service and professional attention to details. As a result of this reputation, Northstone has the honour and privilege of leading some of the highest profile projects in the country.

Staff

We recognize that our primary asset is our people, and that a truly successful company needs to be a rewarding work environment for its staff. Our organization is structured and managed to provide ample opportunity and encouragement for our team to reach their optimum potential. We believe that mutual respect forms the base of our success.

Philosophy

Lasting relationships are the lifeblood of business in our industry. At all times, we strive for solutions that best achieve our clients needs and goals. Our staff ability and commitment to providing these solutions is what distinguishes us. We provide consistent personal and individual attention to all our clients.

ORGANIZATIONAL ETHICS

■ **Professionalism:**

We exercise the highest level of professional and ethical conduct in all our corporate dealings.

■ **Dedication:**

We aspire to be as high as possible and plan responsibly to honour all professional commitment.

■ **Optimism:**

Impossibility never exist in our dictionary, we believe if it can be conceived it can be achieved.

■ **Safety:**

We are relentless in keeping people safe from occupational hazards and we are committed to returning them safe to their families.

■ **Integrity:**

We are very passionate about Honesty, Integrity & Fairness.

■ **Accountability:**

We are accountable for all our professional conduct and we are always candid in our client relations.

■ **Innovation:**

We seek on the best method of achieving success, attacking complacency and encouraging continuous improvements in our processes.

■ **Excellence:**

We are passionate about excellence, understanding that our reputation depends on the value we deliver in the sight of our clients.

■ **Culture:**

We promote an all-inclusive and collaborative work environment where all views are welcome while encouraging transparency, team work and merit.



Our Mission

"Our mission is to remain reliable and efficient at the forefront of the construction industry through quality, honesty, and hard work"

Our Vision:









Our vision is to create and maintain a consortium of highly skilled construction professionals that will continually surpass the expectations of our esteemed clients while earning a fair share on the value we deliver.





Our Expertise:



-  *Prefabricated Building System*
-  *Architecture and Urban Planning*
-  *Civil /Structural Engineering*
-  *Mechanical and Electrical Engineering Design*
-  *Rural Electrification*
-  *Land and Civil Engineering Survey*
-  *Erosion/Flood Control*
-  *Drainage Design and Environmental Engineering*
-  *Commercial, Industrial Structures*

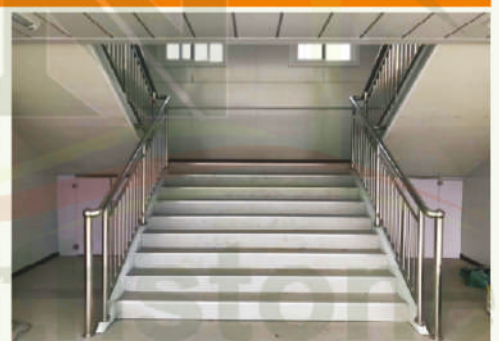

Shelters Limited

RC:1284446



FLAT PACK

PREFABRICATED BUILDING



FLAT-PACK PREFABRICATED BUILDING

Main Steel Structure Frame



Glass wall sandwich panel

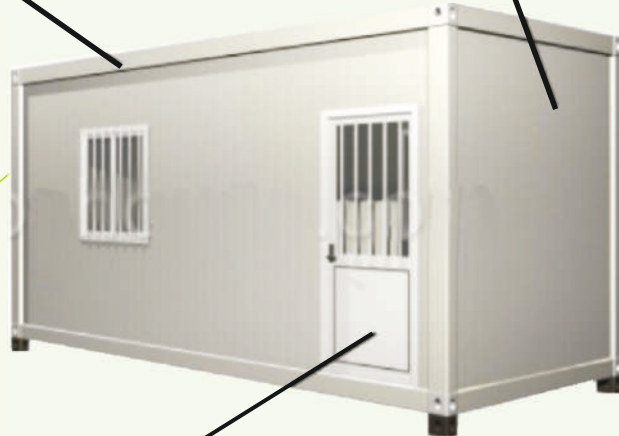
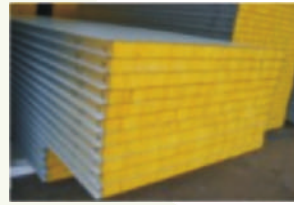

Insulated Steel Door



Aluminium window

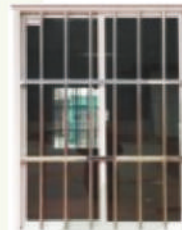

PU Sandwich Panel

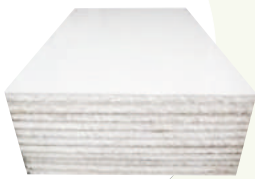

Corner Fitting





Advantages

Prefabricated

All materials of our Flat-Pack solution has been prefabricated in the factory (the roof, chassis, column, wall panel, window, door and electrical system). Clients can easily install our cabins within a short period of time. The prefabricated method significantly shortens the construction time on site. It meets the urgent need for site buildings, government offices and military encampments.

Modular

The standard sizes of our Flat-Pack building are 3.0m x 6.0m x 2.8m, 3.0m x 7.0m x 2.8m, 3.0m x 9.0m x 2.8m and 3.0m x 12.0m x 2.8m. Several units of our prefabricated building can be assembled based on the clients specifications either in suspended floors or combining several units to achieve desired dimensions.

Environment-Friendly

The construction is dry work compared to the conventional brick and mortar structures. No contamination or damage is done to the environment. In addition, The Flat-Pack prefabricated building is portable and movable for next use on a new location. It can also be assembled and disassembled as many times as possible.

Excellent physical property

The main structure of our prefabricated building is a galvanized steel frame and fire proof glass wool Polyurethane sandwich panel (A-Grade fire-proof material) which has excellent performance in fire-proof, sound insulation, heat prevention and earthquake resistance.

Pre-wired

Distribution box, switch, socket for AC and common use, electrical wire for light has been set inside of the roof and wall panel for flexibility when fixing doors, windows and interior partitions.

Modern appearance, optional colours are available for the wall panel and roof.

Our prefabricated building is portable and movable by crane or forklift.

Compared with the conventional building, our prefabricated buildings are easier to assemble, cheaper, saves time and convenient to transport.

The steel structures make the house resist heavy wind of 120km/h and 7 grade earthquake.

All the steel structures are galvanized and can last more than 30 years without discolouration.

No.	Component	Description	Thickness
1	Main Steel Structure	C Steel, Square Tube, Angle Iron, Flat Tube, Round Tube	2.0mm
2	Roof Tile	PU or EPS Tile	20-150mm
3	External Wall Panel	EPS,PU, Rockwool or EPS Cement with Two-sided Galvanized Steel Sandwich Panel	0.5mm for Galvanized Steel Sheet
4	Door	Steel Sandwich Panel Door	900mm (W) x 2100mm (H)
5	Window	PVC Sliding Window	1200mm (W) x 1000mm (H)
6	Flooring	Plywood or PVC	15/20mm
7	Ceiling	PVC or Gypsum Board	8-12mm
TECHNICAL PARAMETER			
No.	Description	Specification	
1	Bearing Load	250kg/square metres	
2	Wind Pressure	0.45KN/Square metres Equal 10 Grade	
3	Earthquake resistance	7 Grade	
4	Temperature Resistance	(-25°C) to 50°C	
5	Life Span	More than 30 years	

FLAT-PACK PREFABRICATED BUILDING



3m X 6m Prefabricated Building



3m X 7m Prefabricated Building



3m x 9m Prefabricated Building



3m X 12m Prefabricated Building



TOP FLAT PLATE



HANGING HEAD



ALUMINUM STEEL WINDOW



POWER BOX



KEY AND LOCKER



LIGHT



HINGES



INSIDE TOP JOINT

Flow Chart

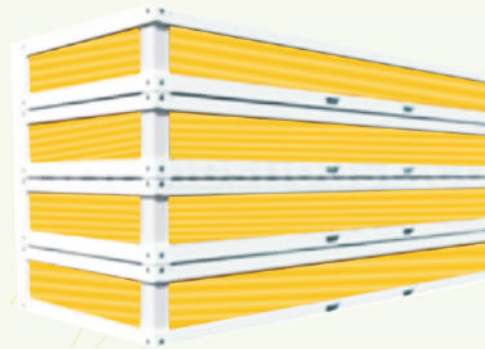
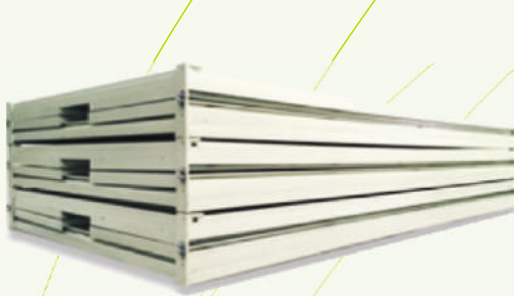
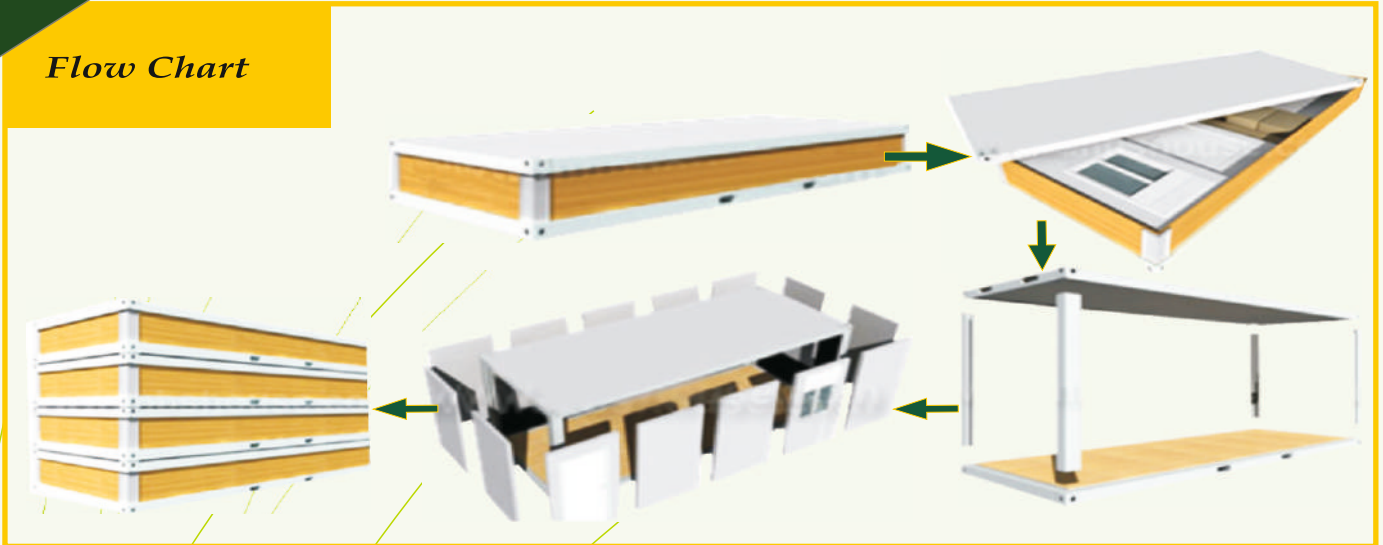

No	Description	Specification
Standard Dimensions		
1	Size	6.0m(L) x 3.0m (W) x 2.8m(H), 7.0m(L) x 3.0m (W) x 2.8m(H)
2		9.0m(L) x 3.0m(W) x 2.8m(H), 12.0m(L) x 3.0m(W) x 2.8m(H)
	Packing Size	CKD
Specification		
1	Frame Structure	2.0mm-4.0mm Cold formed profile steel/ Square tube
2	Decoration	Primer Coat: epoxy zinc-rich primer two layers
		Finishing Coat: alkyd honed paint, white colour, Anti-rust
3	Roof	2mm Bending Steel Plate
4	Ceiling	50mm galvanized steel sandwich panel (or carved metal insulation board)
5	Wall	50mm galvanized steel sandwich panel (or 75mm/10mm)
6	Flooring	15mm CCA cement fibre board + 2mm PVC floor
		(or 12mm/18mm/20mm CCA+10mm composite wood)
7	Door	50mm Metal composite door (glass wool/Phenolic Foam Board)
8	Window	PVC glass sliding windows (4mm thickness glass)
9	Packing	CKD
TECHNICAL PARAMETER		
1	Temperature	(-45 °C) to 50 °C
2	Earthquake Resistance	Grade 8
3	Wind Resistance	120km/h
4	Floor live load	2KN/m ²
5	Roof live load	0.5KN/m ²
6	Life span	more than 30 years

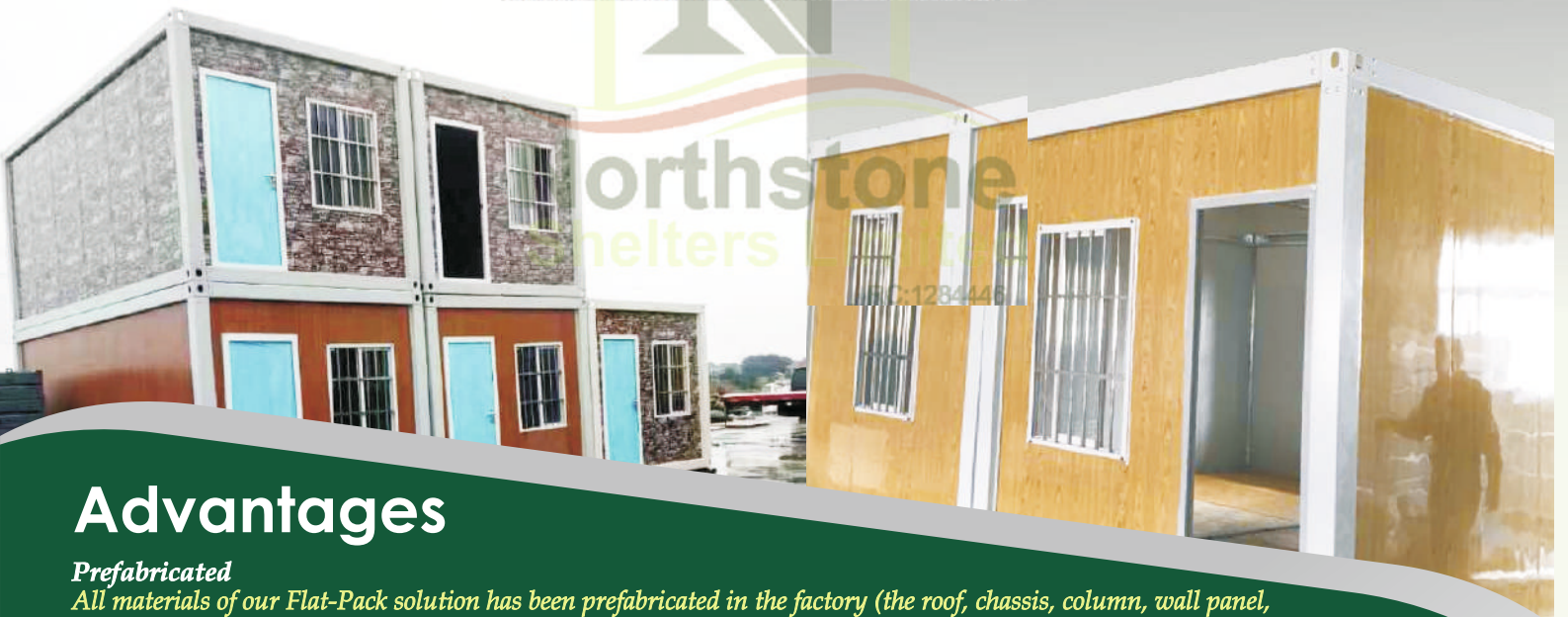
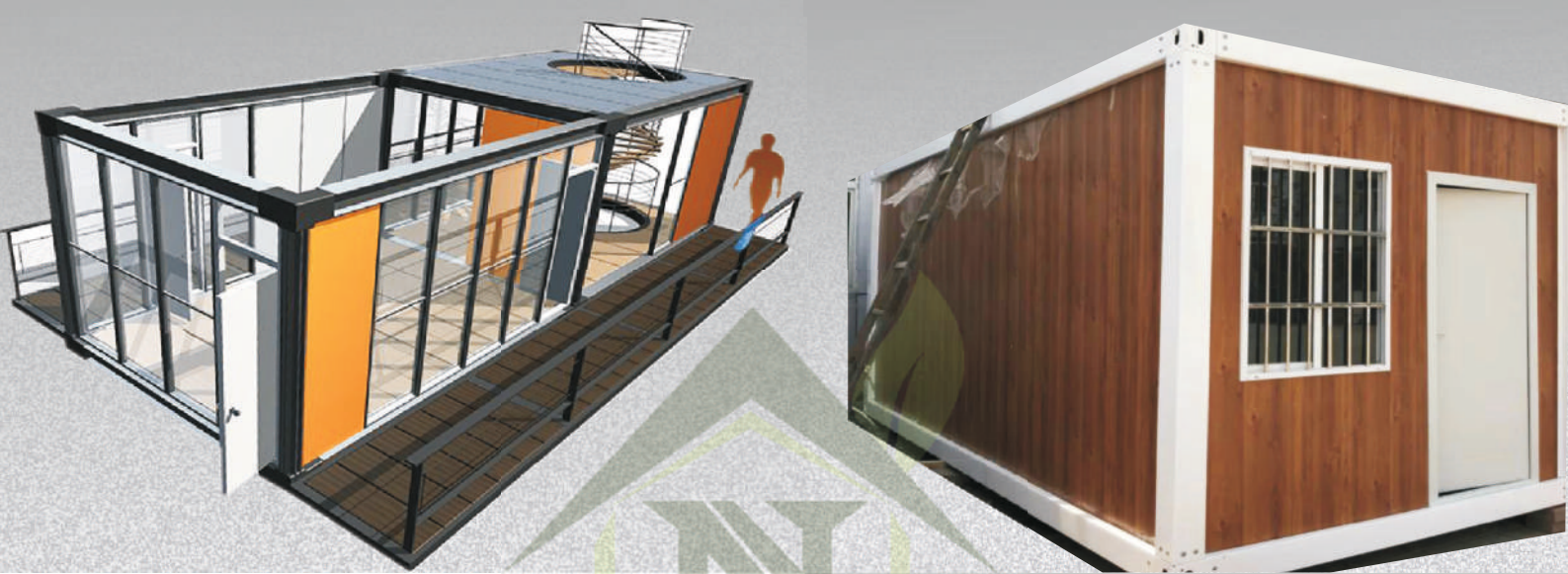

Advantages

Prefabricated

All materials of our Flat-Pack solution has been prefabricated in the factory (the roof, chassis, column, wall panel, window, door and electrical system). Clients can easily install our cabins within a short period of time. The prefabricated method significantly shortens the construction time on site. It meets the urgent need for site buildings, government offices and military encampments.

Modular

The standard sizes of our Flat-Pack building are 3.0m x 6.0m x 2.8m, 3.0m x 7.0m x 2.8m, 3.0m x 9.0m x 2.8m and 3.0m x 12.0m x 2.8m. Several units of our prefabricated building can be assembled based on the clients specifications either in suspended floors or combining several units to achieve desired dimensions.

Environment-Friendly

The construction is dry work compared to the conventional brick and mortar structures. No contamination or damage is done to the environment. In addition, The Flat-Pack prefabricated building is portable and movable for next use on a new location. It can also be assembled and dissembled as many times as possible.

Excellent physical property

The main structure of our prefabricated building is a galvanized steel frame and fire proof glass wool polyurethane sandwich panel (A-Grade fire-proof material) which has excellent performance in fire-proof, sound insulation, heat prevention and earthquake resistance.

Pre-wired

Distribution box, switch, socket for AC and common use, electrical wire for light has been set inside of the roof and wall panel for flexibility when fixing doors, windows and interior partitions.

Modern appearance, optional colours are available for the wall panel and roof.

Our prefabricated building is portable and movable by crane or forklift.

Compared with the conventional building, our prefabricated buildings are easier to assemble, cheaper, saves time and convenient to transport.

The steel structures make the house resist heavy wind of 120km/h and 7 grade earthquake.

All the steel structures are galvanized and can last more than 30 years without discolouration.



FOLDABLE PREFABRICATED BUILDING



FOLDABLE PREFABRICATED BUILDING

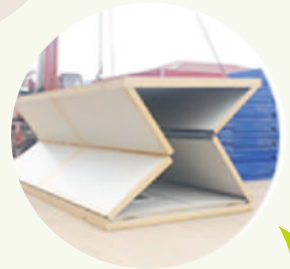

No.	Component	Description	Thickness
1	Main Steel Structure	C Steel, Square Tube, Angle Iron, Flat Tube, Round Tube	2.0mm
2	Roof Tile	PU or EPS Tile	20-150mm
3	External Wall Panel	50mm-250m EPS, PU, Rockwool or EPS Cement with Two-sides galvanized Steel Sandwich Panel	0.5mm for galvanized Steel Sheet
4	Door	Steel Sandwich Panel Door	900mm (W) x 2100mm (H)
5	Window	PVC Sliding Window	1200mm (W) x 1000mm (H)
6	Flooring	Plywood or PVC	15/20mm
7	Ceiling	PVC or Gypsum Board	8-12mm

TECHNICAL PARAMETER

No.	Description	Specification
1	Bearing Load	250kg/square metres
2	Wind Pressure	0.45KN/Square metres Equal 10 Grade
3	Earthquake resistance	7 Grade
4	Temperature Resistance	(-25°C) to 50°C
5	Life Span	More than 30 yearsn

FOLDABLE PREFABRICATED BUILDING



TOP FLAT PLATE



HANGING HEAD

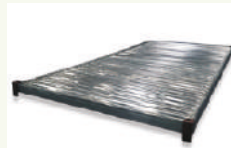

TOP ROOF



STRUCTURE



ASSEMBLED



ALUMINUM STEEL WINDOW



POWER BOX



DISSEMBLE THE FRONT AND REAR SIDE

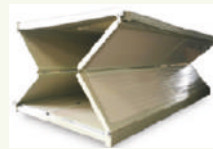

FOLDING



PACKING



KEY AND LOCKER

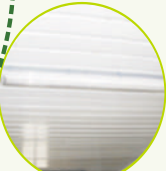

LIGHT



HINGES



INSIDE TOP JOINT



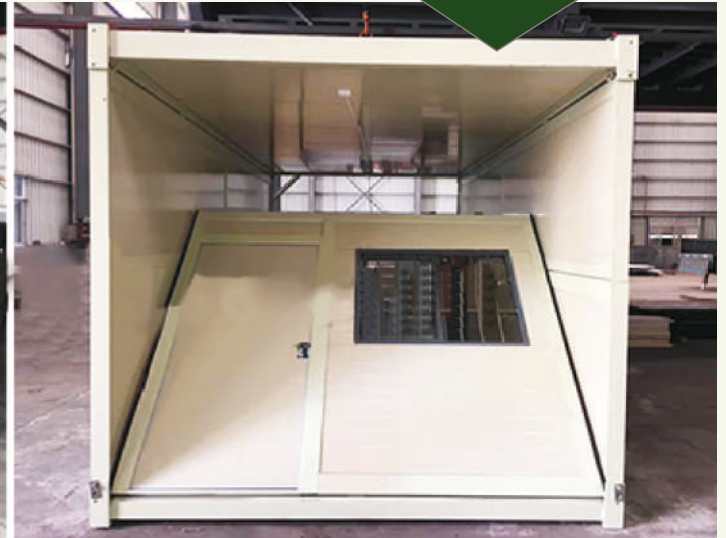
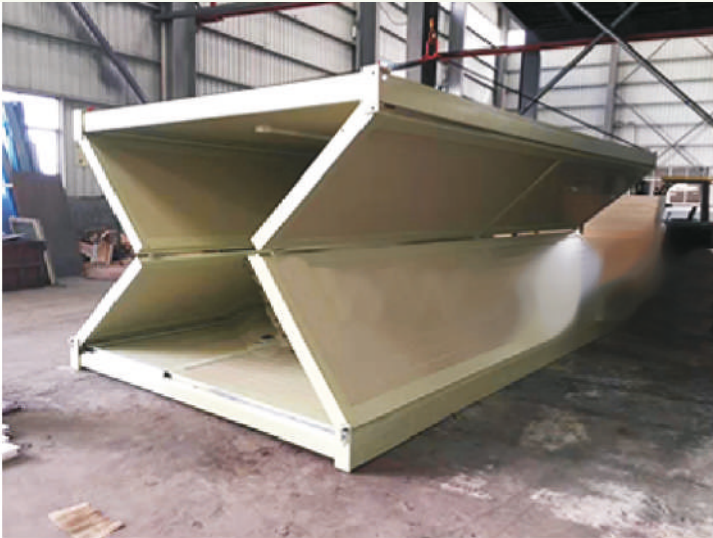

Advantages

Prefabricated

All materials of our Flat-Pack solution has been prefabricated in the factory (the roof, chassis, column, wall panel, window, door and electrical system). Clients can easily install our cabins within a short period of time. The prefabricated method significantly shortens the construction time on site. It meets the urgent need for site buildings, government offices and military encampments.

Modular

The standard sizes of our Flat-Pack building are 3.0m x 6.0m x 2.8m, 3.0m x 7.0m x 2.8m, 3.0m x 9.0m x 2.8m and 3.0m x 12.0m x 2.8m. Several units of our prefabricated building can be assembled based on the clients specifications either in suspended floors or combining several units to achieve desired dimensions.

Environment-Friendly

The construction is dry work compared to the conventional brick and mortar structures. No contamination or damage is done to the environment. In addition, The Flat-Pack prefabricated building is portable and movable for next use on a new location. It can also be assembled and disassembled as many times as possible.

Excellent physical property

The main structure of our prefabricated building is a galvanized steel frame and fire proof glass wool sandwich panel (A-Grade fire-proof material) which has excellent performance in fire-proof, sound insulation, heat prevention and earthquake resistance.

Pre-wired

Distribution box, switch, socket for AC and common use, electrical wire for light has been set inside of the roof and wall panel for flexibility when fixing doors, windows and interior partitions.

Modern appearance, optional colours are available for the wall panel and roof.

Our prefabricated building is portable and movable by crane or forklift.

Compared with the conventional building, our prefabricated buildings are easier to assemble, cheaper, saves time and convenient to transport.

The steel structures make the house resist heavy wind of 120km/h and 7 grade earthquake.

All the steel structures are galvanized and can last more than 30 years without discolouration.



EXPANDABLE PREFABRICATED BUILDING



EXPANDABLE MODULAR PREFABRICATED BUILDING



No.	Description	Specification
Standard Dimensions		
1	Size	6.0m(L) x 6.5m(W) x 2.8m(H)
2	Packing Size	CKD
Specification		
1	Frame Structure	2.0mm-4.0mm Cold formed profile steel/Square tube
2	Decoration	Primer Coat: epoxy zinc rich primer two layers
		Finishing Coat: alkyd honed paint, white colour, Anti-rust
3	Roof	2mm Bending steel plate
4	Ceiling	50mm galvanized steel sandwich panel (or carved metal insulation board)
5	Wall	50mm galvanized steel sandwich panel (or 75mm/10mm)
6	Flooring	18mm CCA cement fibre board +2mm PVC floor
		(or 12mm/18mm/20mm CCA+10mm composite wood)
7	Door	50mm Metal composite door(glass wool/Phenolic Foam Board)
8	Window	PVC sliding glass window (4mm thickness glass)
9	Packing	CKD
TECHNICAL PARAMETER		
1	Temperature	(-45 C) 50 °C
2	Earthquake resistance	Grade 8
3	Wind Resistance	120m/h
4	Floor live Load	2KN/m ²
5	Roof live load	0.5kN/m ²
6	Life Span	more than 30 years



EXPANDABLE MODULAR PREFABRICATED BUILDING

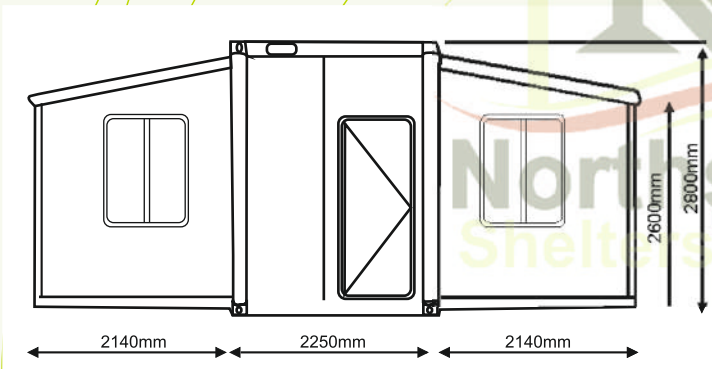
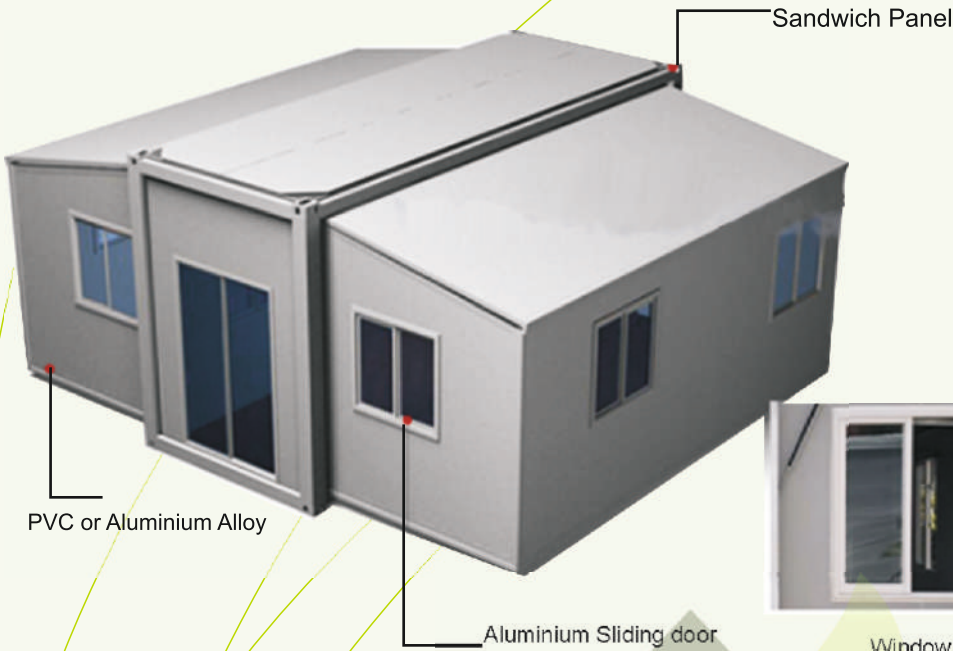



LOW COST LIGHT STEEL FRAME MODULAR PREFABRICATED VILLA

LOW COST LIGHT STEEL FRAME MODULAR PREFABRICATED VILLA



Advantages:

1. *Easy to install: 25-30m² can be installed per day.*
2. *Easy to disassemble, anyone can disassemble a 40-50m² house in one day.*
3. *Service life: 30-50 years for one-time assembly, 30 years for at least 15 times assembly*
4. *It promotes a healthy and safe environment and the materials can be recycled*
5. *Competitive price, compared with conventional construction.*
6. *Light and reliable, the steel structure is strong and firm.*
7. *Good water proof, moisture proof, heat insulation and sound insulation capacity*
8. *Diversified Specification: Our design can be customized.*
9. *Practical good space utilization and high price performance.*

Flow Chart

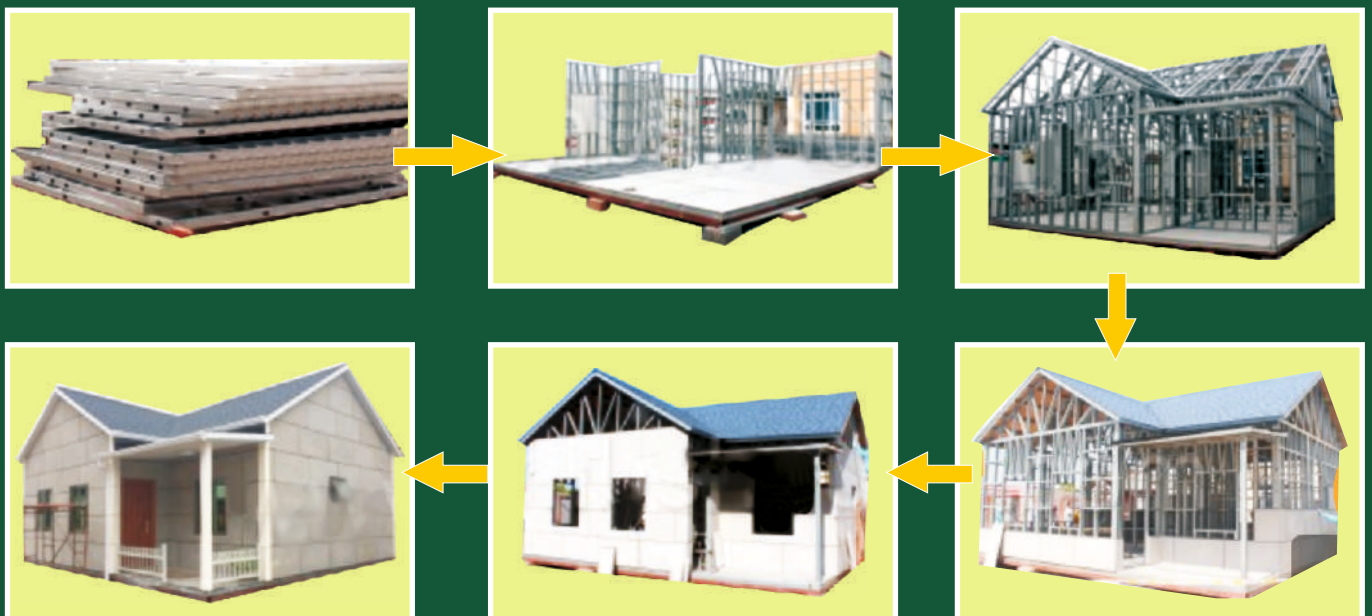



MODULAR PREFABRICATED GUARD HOUSE



MODULAR PREFABRICATED GUARD HOUSE



ITEM	COMPONENT	DESCRIPTION
Steel	Main Structure	Q550 galvanized steel/square tube/1 beam / C section
Frame	Antiseptic Treatment	Painting / galvanization
	Basic Wall	OSB board/cement fibre board, moisture proof Membrane, insulated sandwich panel
Wall	Exterior Wall	PVC decorative cladding, or carved metal insulation board (optional customized decoration: like stone, ceramic)
	Interior Wall	Carved metal insulation board (optional customized decoration: like wall paper, ceramic)
Roof	Basic Roof	OSB board, SBS water proof membrane
	Exterior Roof	Decorative roofing, glazed tile/corrugated metal sheet / synthetic resin tile / fibre asphalt tile
	Water proofing	SBS water proof membrane
	Ceiling	Carved metal insulation board (optional as plaster, PVC, aluminium)
Accessories	Door	Aluminum Alloy door(optional as metal stainless steel door with wooden pattern)
	Window	PVC or Aluminium
	Flashing/Trim	Colour steel sheet
	Sealant	Glue
	Bolts / Screws/Nails	Metal

MODULAR PREFABRICATED GUARD HOUSE





PREFABRICATED MOBILE TOILET

PREFABRICATED MOBILE TOILET



Aluminum Column



Wall Panel
Eps Sandwich Panel



Roof Panel
Eps Sandwich Panel



Exhaust fan



Anti-skid aluminum plate



Bathroom Chassis

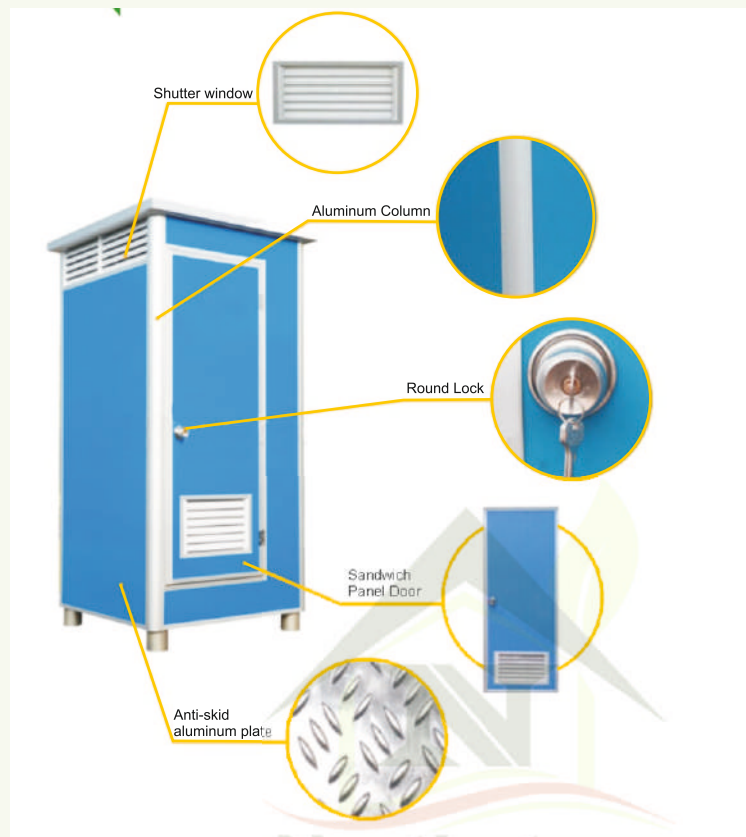

Item	Specifications	QTY	Unit
Wall Panel	EPS sandwich panel, thickness of steel metal is 0.5mm	4	pcs
Roof Panel	EPS sandwich panel, thickness of steel metal is 0.5mm	1	pcs
Door (900mm high)	EPS sandwich panel, thickness of steel metal is 0.5mm	1	pcs
Base	Thickness of the angle steel is 2mm, steel plate 3mm	1	pcs
Sitting/Squat Toilet	Ceramic (good package to protect it when loading)	1	pcs
Washing Basin	Ceramic	1	set
Water Pipe for	PVC water pipe	1	set
Paper Hanger	PVC	1	unit
Locker	Stainless steel	1	unit
Accessories	Water proof glue, Battery Exhaust Fan, Battery LED Light switch, stainless steel shower, Stainless steel tap, hook	1	unit

PREFABRICATED MOBILE TOILET



Northstone
Shelters Limited

RC:1284446



HPD MOBILE TOILET





Product Advantages

- ★ Cost effective
- ★ Strong steel kit frames
- ★ Utilizing recycled materials
- ★ Easy to build and saves time
- ★ Minimum waste during manufacture
- ★ Fire, pest and cyclone resistant
- ★ Custom designs to suit various land topographies

Item	PT100	PT200	PT350
Toilet Style	Sitting Toilet	Squat Toilet	Squat Toilet
Size: mm	1.2m x 1.1m x 2.4m	1.2m x 1.1m x 2.3m	1.2m x 1.4m x 2.5m
Weight: kg	110	110	110
Water Tank: L	110	50	20
Waste Tank: L	300	100	80
Loading	20GP/40HQ:15pcs/30pcs (take apart)	20GP/40HQ:15pcs/40pcs (take apart)	20GP/40HQ:15pcs/40pcs (take apart)
Standard Facilities	Flushing toilet Hand wash basin		
Optional Facilities	Articulate, Exhaust fan, Metal Base for Forklift(or special request from client)		
Panel color	Grey/Blue/Red/Yellow (customized)		
Sitting Toilet	Marble Style		
Wash Basin	Marble Style		

HPD MOBILE TOILET



Exhaust Pipe

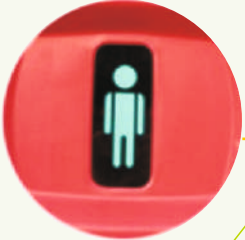

Male/Female Signs

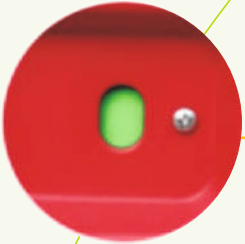

Available/Occupied Signs



Crane Hook



Mirror



Hanger



Wash-basin



Foot Pump



Marble Color Toilet



Metal Base for Forklift/Crane



Northstone Shelters Limited

RC:1284446



CONVENTIONAL BUILDING STRUCTURES

CONVENTIONAL BUILDING STRUCTURES





OUR CLIENTS





Our Clients



Zenith Bank Plc



Shell



Nigeria Police Force



MTN Nigeria



Globacom Limited



Nigeria Custom Service



Nigerian Army



Guarantee Trust Bank



NNPC



Airtel Nigeria



Nigerian Navy



Chevron



A.A. Rano Nigeria Ltd.



United Bank for Africa



Rahamaniyya Oil & Gas



Forte Oil Plc



Diamond Bank Plc



Etisalat Nigeria Ltd.



Unicef



Nigerian Communication Commission



European Union



Oando Filling Station



Nigeria Immigration Service



Action Against Hunger



Medecins Sans Frontiere

Organization Chart

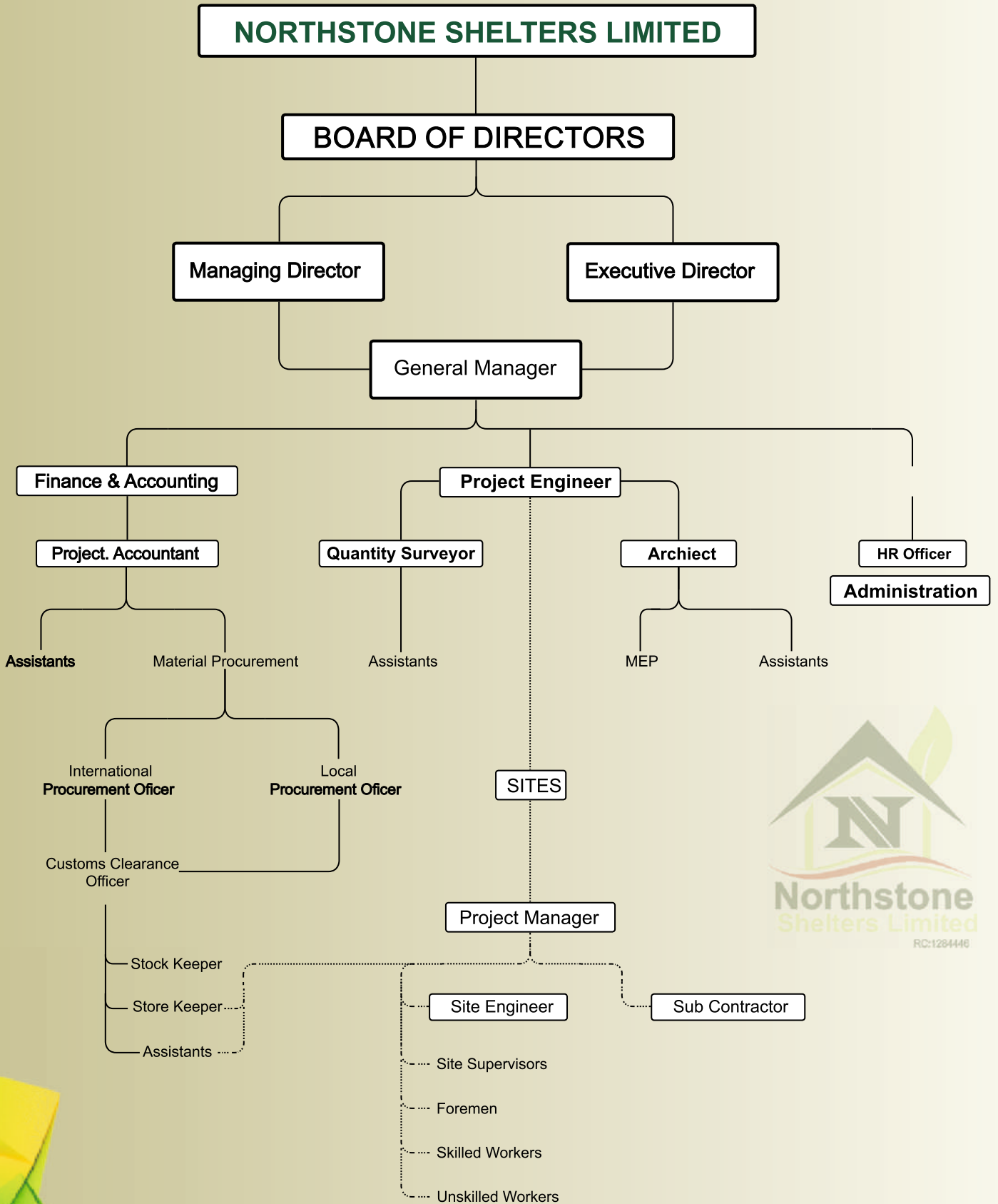



OUR PROJECTS



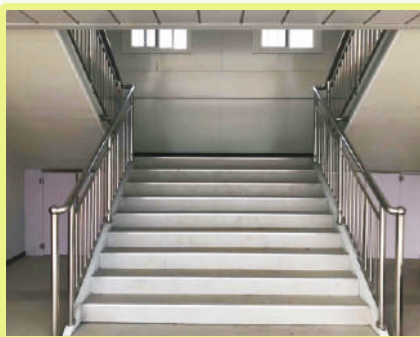



Northstone
Shelters Limited
RC-1284448



Our Projects:

















**CORPORATE AFFAIRS COMMISSION
FEDERAL REPUBLIC OF NIGERIA**

Certificate of Incorporation

I hereby certify that

NORTHSTONE SHELTERS LIMITED

is this day incorporated under the COMPANIES AND ALLIED MATTERS ACT 1990 and that the Company is Limited By Shares.

Given under my hand at Abuja this 31st day of August, 2015.

**Northstone
Shelters Limited**

RC:1284448



BELLO MAHMUD



No.00000080083

NIGERIA SOCIAL INSURANCE TRUST FUND ECS CLEARANCE CERTIFICATE

ORIGINAL

Employer Registration No.1004000318

This is to Certify that

NORTHSTONE SHELTERS LIMITED

RC No 1284446

Has complied with the provisions of the Employees' Compensation ACT, 2010 (ECA 2010).

The details of compliance are as follows:

Description	Year 2018	Year 2019	Year 2020
Number of Employees	3	3	3
ECS Contribution Level	PAID	PAID	PAID

This Certificate expires on...31ST DECEMBER, 2020



[Signature]
Approved Signature



Federal Republic of Nigeria Industrial Training Fund



CERTIFICATE OF COMPLIANCE

This is to certify that **NORTHSTONE SHELTERS LIMITED**

Address **HOUSE 1, A CLOSE, 7TH AVENUE GWARIMPA, ABUJA**

Has complied with year **2019** Industrial Training Fund Contribution in accordance with the Laws of the Federal Republic of Nigeria cap. 19 Laws of the Federation Section 6 subsections (1), (11), (111) of 2011 as amended

REGISTRATION NO. **GWA-005-2458**

RECEIPT NO. **000234657**

THIS CERTIFICATE EXPIRES 31ST DECEMBER **2020**

DAVID N. KWAPLENG

Name and Signature
Head Revenue Inspectorate
& Compliance

Area Office Stamp



AMINU LABO

Name and Signature
Area Manager



**Northstone
Shelters Limited**
RC:1284448



0059757

Original



National Pension Commission

Pension Clearance Certificate PR0001284446

Employer Code _____

This is to Certify that

NORTHSTONE SHELTERS LIMITED RC. No 1284446

has complied with the provisions of the Pension Reform Act 2004

The details of compliance are as follows:

Description	2017 Year.....	2018 Year.....	2019 Year.....
Number of Employees	3	3	3
Pension Contributions Remitted to Employees RSAs (N)	116,640.00	116,640.00	116,640.00
Sum Assured for Group Life Insurance	-	-	1,980,000.00

This certificate expires on **31 DECEMBER, 2020**



Official Date Stamp Impression

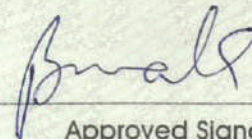

Approved Signatory

UTAKO MICRO & SMALL TAX OFFICE

WILDOT PLAZA, PLOT 903, OBAFEMI AWOLOWO WAY, BEHIND ACCESS BANK, UTAKO DISTRICT, ABUJA.
utakomsto@firs.gov.ng, www.firs.gov.ng
Tel: 08115906284, 08115902277

Our Ref No. UT/06/18400341-000/VAT/4

05/04/2017
Date

THE MANAGING DIRECTOR
NORTHSTONE SHELTERS LIMITED
HOUSE 1, A CLOSE, 7TH AVENUE, GWARINPA
ABUJA.

TAX REGISTRATION

1. We acknowledged receipt of your application for VAT Registration in compliance with Section 8(1) of the Value Added Tax Act, 102 of 1993
Please, be informed that your VAT Registration is TIN:-18400341-0001/VAT/4 and you are by this registration authorized to collect and remit VAT on behalf of the Federal Inland Revenue Service (FIRS).
2. You are to note that all registered companies are not exempted from rendering returns on monthly basis whether they are dealing on exempted goods/services or not; or whether they are in business or not once registered.
3. Also note that failure to render the monthly returns attracts a penalty of N5, 000.00 for each month of default.
4. Please, always quote this number in all your correspondence with this office.

RC:1284446

Congratulations.

Yours faithfully,



TCC NO : 10581411
TAX OFFICE : MSTO UTAKO(UTKA)
DATE : 06-Feb-2020

TAX CLEARANCE CERTIFICATE

Name of Company : NORTHSTONE SHELTERS LIMITED



RC NO : RC1284446
Date of Incorporation : 31-08-2015
TIN : 18400341-0001
Effective Business Address : HOUSE 1, A CLOSE, 7TH AVENUE, GWARINPA ABUJA FCT

This is to certify that the above named company has rendered Income Tax, Value Added Tax, Information Technology Development Levy, Education Tax, as well as other tax returns and paid the assessed taxes in accordance with the relevant tax laws for all years including the past three assessment years as detailed hereunder:-

	Assessment Year 2017	*Nature	Assessment Year 2018	*Nature	Assessment Year 2019	*Nature
Turnover	61,192,050.00		61,192,050.00		42,290,044.00	
Assessable Profit/Loss	1,105,000.00		1,105,000.00		1,067,500.00	
Total Profit	368,333.00		368,333.00		355,833.00	
Tax Payable	747,103.00	ADMI	2,312,500.00	ADMIN	106,750.00	ADMIN
Tax Paid-Companies Income Tax Receipt No	ABP/933654		ZIB/32155			
Date	17-Jun-2017		21-Nov-2017			
Tax Outstanding (If any)	NIL		NIL		NIL	
Petroleum Profit Tax Receipt No. & Date						
Tax Outstanding (If any)	NIL		NIL		NIL	

*Nature of Assessment: (i) Best of Judgement (ii) Self Assessment (iii) Minimum Tax (iv) Pre-Operation Levy (POL) (v) Government (Additional, Audit, Investigation) (vi) Others (Please Specify)

Source of Income :
Other comments :
This Certificate Expires On : 30th of June 2020
(Not Later than the end of the current year of Assessment)



Official Stamp Impression

Alkali Salihu
State Coordinator
Name & Rank Of Approving Officer





Northstone
Shelters Limited

RC:1284448



Head Office:
Plot 1029 Kubwa Express way Opp. Dan Oil Jahi District, Abuja
Tel: 08178922222, 08099888889, 09092555551 **Email:** supports@northstoneshelters.com,
Website: www.northstoneshelters.com